

NOTES:

1. DIECAST BODY, NICKEL PLATED.
2. DELRIN INSULATOR.
3. GOLD PLATED, BRASS CONTACT, .000003.
4. PACKAGED IN BAG 999-361.
5. USE AMPHENOL CRIMP TOOL #CTL-1.
6. CAPTIVATED CONTACT, .030 WIRE ENTRY.
7. 3 PC. (BODY, FERRULE, CONTACT).
8. BUSHING SUPPLIED FOR RG-62 CABLE.
9. DO NOT SCALE THIS DRAWING.
10. UNLESS OTHERWISE SPECIFIED, ALL DIMENSIONS ARE AFTER PLATING.

<b>31-321-RFX</b>		REVISIONS			
DRAWING NO.	REV	DESCRIPTION	DATE	ECO	APPR
THIRD ANGLE PROJ.	A	RELEASE TO MFG.	10/2/91	38063	DR
	B	SEE SHEET 1	1/15/99	42788	CPM/

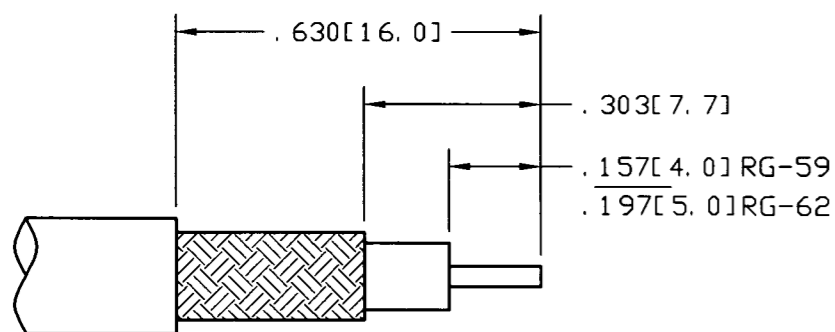
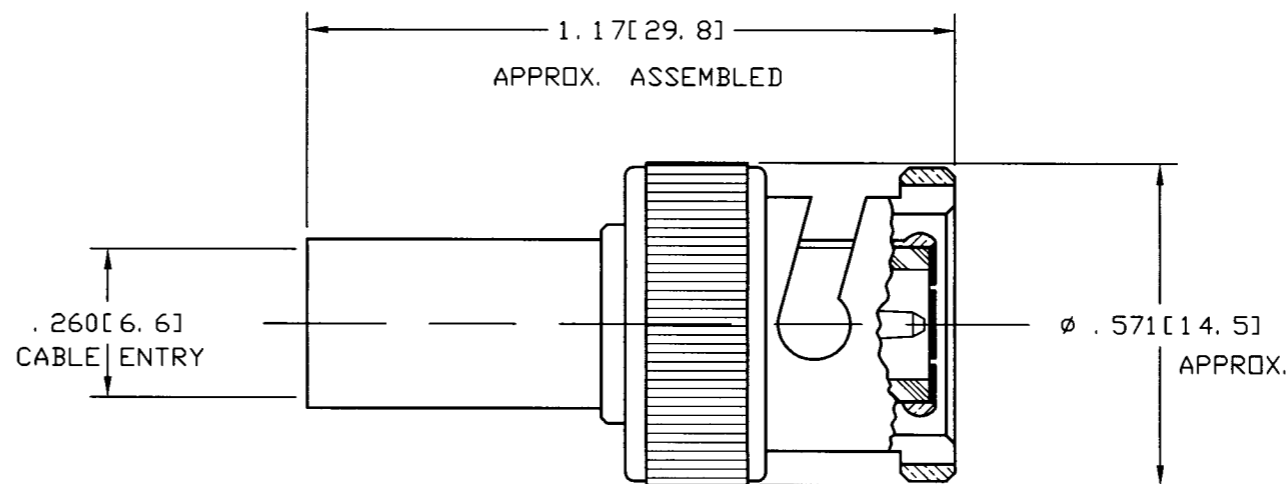

RECOMMENDED CABLE STRIPPING DIM'S

CUSTOMER OUTLINE DRAWING

ENGLISH [METRIC]

UNLESS OTHERWISE SPECIFIED, DIMENSIONS ARE IN INCHES AND TOLERANCES ARE: 2 PLACE DECIMAL ±.015 (0,381 mm)    3 PLACE DECIMAL ±.005 (0,127 mm)    ANGLES ± 1'	MATERIAL	DRAWN C. McGRATH	DATE 12/17/98	TITLE BNC CRIMP CRIMP PLUG FOR RG-59, 62 CABLE 50 OHM	<b>Amphenol</b> Amphenol Corporation RF/Microwave Operations Danbury, Conn. U.S.A. 06810 SCALE: 3:1    SHEET 2 OF 2	
	REFERENCE EAR 962370	ENGINEER T. AUBIN	DATE 12/17/98	APPROVED 		DATE 1/15/99
NOTICE - These drawings, specifications, or other data (1) are, and remain the property of Amphenol Corp. (2) must be returned upon request; and (3) are confidential and not to be disclosed to any person other than those to whom they are given by Amphenol Corp. The furnishing of these drawings, specifications, or other data by Amphenol Corp., or to any other person to anyone for any purpose is not to be regarded by implication or otherwise in any manner licensing, granting rights or permitting such holder or any other person to manufacture, use or sell any product, process or design, patented or otherwise, that may in any way be related to or disclosed by said drawings, specifications, or other data.		CAD FILE H:\DEPT611\BNC\031\ASSY\321\RFXSHT2	CODE ID 74868	DWG SIZE B	DRAWING NO. 31-321-RFX	REV B