

OS5/OS9 Optical Stars

Create Serial Data Networks



For Reliable Substation Communications

Technical Description

OS5HRT and OS9HRT Optical Stars provide network designers with a convenient “hub and spoke” topology capability. Optical Stars are available with either five or nine ports, with multi-mode and/or single-mode optics providing a full optical budget on each port. To further provide flexibility the Master port (port one) can be configured with an RS232 copper interface. The OpticalStar can in addition support Master/Slave or Peer-to-Peer mode and be cascaded by simply connecting a port from one Optical Star to a port of the next (in Master/Slave mode it must be a slave port connected to the next master).

DYMEC Optical Stars are ideal for Master/Slave polling applications such as multiple meters, relays and other statistical devices as well as broadcasting IRIG-B to multiple devices where fiber offers extended range and isolation from interference. Optical Stars also allow you to take one or more devices out of service while all others continue to operate. This is invaluable in most applications.

Optical Stars are passive to all software protocols, and ports cannot be addressed by software. Data rates from dc to 2M bps are supported. Optical Stars are optically compatible with **DYMEC** models 5843, 5844, 5845 and 5846, as well as all 3900 Chassis serial cards and all serial optical ports of the DynaStar products. Optical Stars are also compatible with most IEDs with embedded optical ports using amplitude modulation. These units are available in 19-inch rack mount and can be configured for panel mounting.

Features and Benefits

- 5 and 9 port Fiber Optic Serial Stars enables networking of multiple Serial devices.
- Optic Serial Stars allow any Intelligent Electronic Device (IED) to de-energize without effecting the rest of the net-work.
- Extended distances of 5km with Multi-mode fiber and >25km with Single-mode fiber.
- Data Rates: dc to 2 Mbs. Can support any mix of RS 232 or 422/485 with DYMEC Links.
- Each data channel has its own diagnostic LED for easier debug of installation.
- Operating temperature of -40°C to +85°C.
- 5-Year warranty.
- Powered from Station battery bus to IEEE 1613 and C37.90
- Multimode and/or Single Mode Fiber.
- 19-inch rack or panel mount.
- Conformal coating of PC boards.
- Packaged in rugged, industrial-quality Galva Neal and powder coated shells.

OS5/OS9 Specifications

	Multimode	Single-mode
Optical Parameters @ Max Temp		
Optical Budget Typical	19.5 dB	18 dB
Output power Typical	-10.5 dBm peak	-11.5 dBm peak
Receiver Sensitivity Typical	-30 dBm peak	-33.5 dBm peak
	62.5µ/125µ Multimode	9µ/125µ Single-mode
Center Wavelength	850nm	1310nm
Connector Type	ST	ST
Fiber Type	Multi-Mode (50-200µm)	Single-mode (9-13µm)
Data Rate	DC to 2M bps	DC to 2M bps
Data Transmission	Asynchronous, simplex or Half Duplex	Asynchronous, simplex or Half Duplex
Transmission Distance	up to 5000 meters	~ 30K meters
	62.5µ/125 Cable@3dB/km	9µ/125 Cable@0.5dB/km
Bit Error Rate	10-E9 Max.	
Input to Output Delay	300 nsec Max	
Ambient Temperature		
Operating Temperatures	-40° to +85° C	-40° to +70° C
Storage Temperature	-40° to +85° C	
Electrical		
Power Required	~27.5 Watts	
Input Current	250 mA @ 90-250 V	
	1.25 A @ 18-60 V	
RS232 Copper Master Port		
Data Connector	9 Pin D-Type Female	
	Fixed DCE only	
Data Rate	DC to 250 Kbps	
Input Impedance	>3000Ohms	
Input Voltage	+/- 30 Volts Max	
Output Impedance	>300 Ohms	
Driver Output	+/- 5 V min into 3000 Ohms	
Mechanical		
Weight	~11 Lbs	
Power Dissipation BTU/H	9 BTU	
Dimensions Inches	19W X 9D X 3.5H	
Configuration (Switches)	Master/Slave or Peer to Peer	
Indicators	Power	
	Data Collision	
	Master/Slave Mode	
	Peer to Peer Mode	
	Master Port	
	Transmit Each Port	
	Receive Each Port	
Specifications subject to change without notice		

Sample Applications

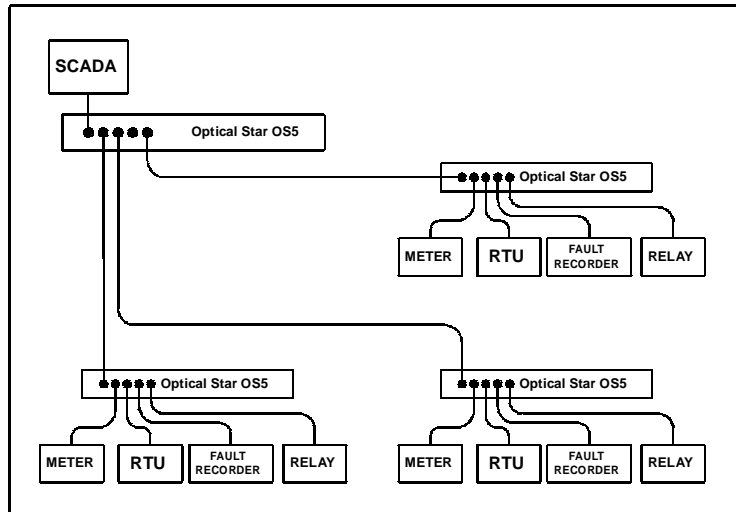

Cascading a single SCADA Master to multiple substations or multiple locations within a large substation

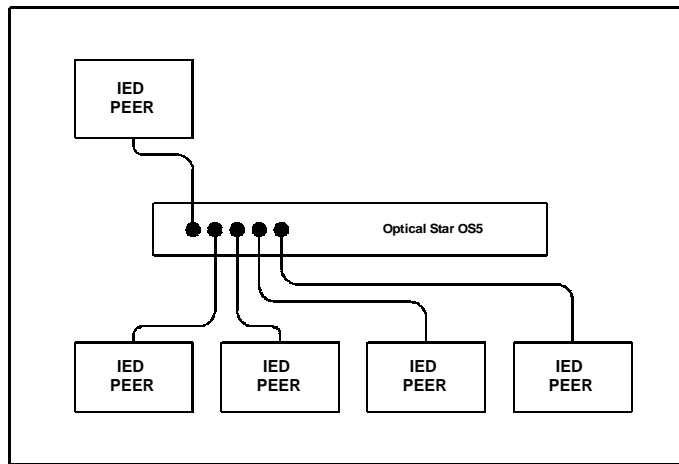

Peer to Peer Operation

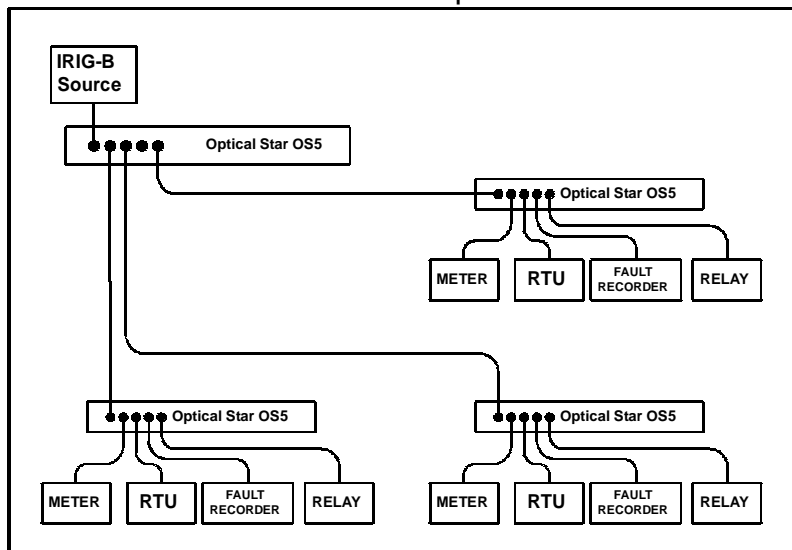

IRIG-B timing signal distribution through cascaded Optical Stars
To multiple cabinets or substations

Ordering Information

ORDERING METHOD FOR OS5 AND OS9 OPTICAL STARS

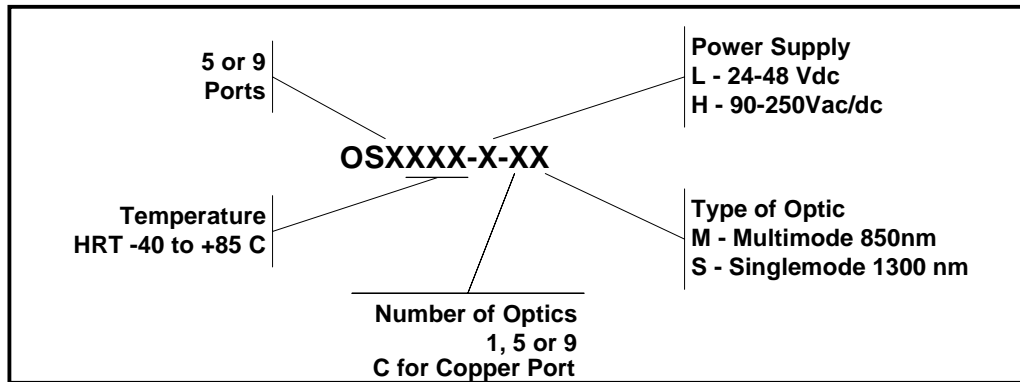

Example:

OS5HRT-H-CM:

Total of 5 Ports Master RS232 Copper
-40 to +85 C Temperature Range
90-250 Vac/Vdc Input Power
4 Multimode Optical Ports

OS9HRT-L-1S:

Total of 9 Ports
-40 to +70 C Temperature Range
24-48 Vdc Input Power
1 Single-mode and 8 Multimode Optical Ports

- ACC-SWMB Optional Wall Mount Bracket
- ACC-SRMB Rack Mount Bracket (Supplied with Optical Star)
- ACC-CBL1 Optional DB9 Male 3M Pigtail Cable

Outline Drawing Model OS5-9

